

Household sanitation

Part of a series of WaterAid technology briefs.

Available online at www.wateraid.org/technologies

January 2013

Introduction

Open defecation in fields, bushes or beaches results in disease-causing pathogens being spread freely, and should be prevented. There are many designs of latrine, ranging from a simple pit with a slab and superstructure, to a double vault composting latrine producing high quality organic fertiliser, and any of these will effectively contain faecal pathogens (provided they are well used and maintained). Pit latrines have proven to be a popular choice with many people in various countries and are highly affordable; however it is important that people are given the opportunity to examine a variety of options and decide which they would prefer. Given sensitive guidelines and a little technical help, families can build latrines for themselves at very low cost.

It should be noted that latrines are only one part of a sanitation system, particularly in urban areas. This technology note is concerned solely with on-site sanitation. For decentralised systems and collection and treatment of sludge please refer to the technology note 'Wastewater treatment'.

There are three main components in latrine design:

- Pit
- Slab
- Superstructure

Many variations of each component exist, which can be interchanged to design an optimum solution for a particular area.

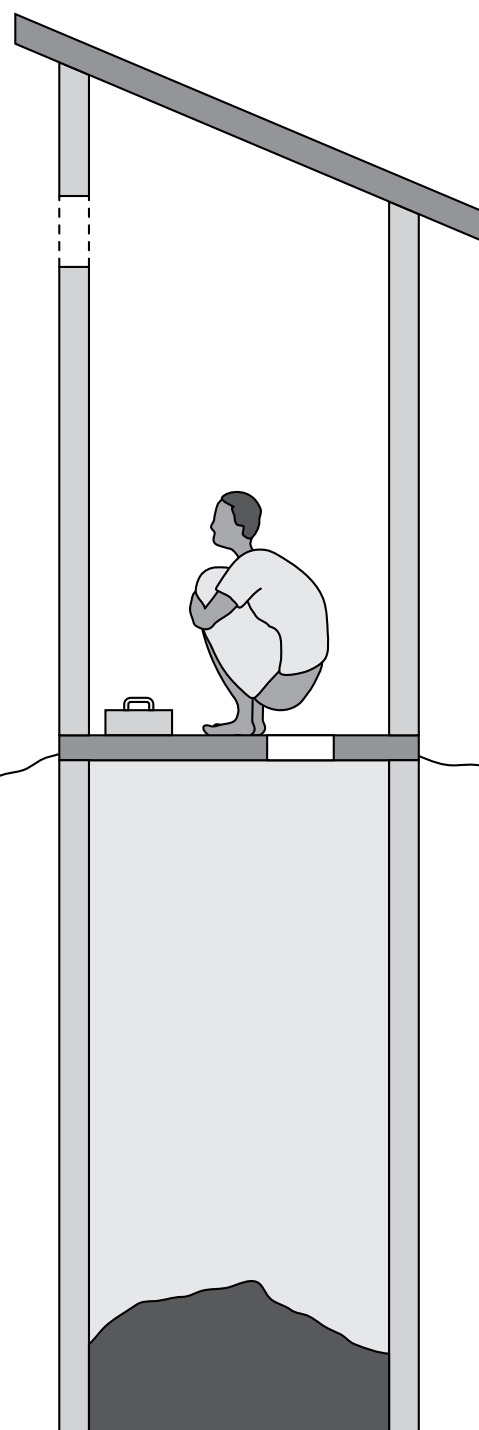

Main components

Pit

The pit for a family latrine should be about 1.2m in diameter (this is the smallest dimension that can be dug conveniently), with the base of the pit above the water table. The pit can be built (partially or wholly) above ground level and the depth should generally be around 1.5m but can be as deep as 3m. This is influenced by family size and decisions around how latrines will be emptied. Specifics will depend on the particular context: for example, urban areas or composting latrines might require shallow pits with frequent emptying; in unstable ground the pit walls should be supported with timber, cement rings, stones or trapezoidal blocks.

A twin pit system, with the superstructure and slab being used over the two pits alternately, allows one pit to be in use whilst the contents of the other are left to naturally biodegrade and can have a virtually unlimited life.

Slab

Slabs generally come with either a simple hole, a pour-flush pan (which can come with or without a water seal), or a urine diversion system which separates faeces and urine. The type of slab used depends on the type of household latrine treatment system in place, as detailed below. Most slabs can be easily adapted to any of the three types. If the latrine is also to be used for bathing, it might be preferable to have a larger slab, but ideally washing water should be diverted to a separate soakaway.

The slab needs to be strong and easy to keep clean. Concrete is a good material, and should be used in combination with steel reinforcement. If none is available, strength can be achieved by using a domed shape. Raised “footpads” should be cast into the slab and, unless of a domed

design, the slab should be shaped so that liquid drains towards the central hole. Larger slabs should not be cast over the pit, and should be preferably cast in two pieces (for easier transport). Casting a slab in a round shape, rather than square, means that it can be rolled to its destination.

If the slabs are to be made within the communities, they should be supplied with well-designed steel or timber shuttering for the casting, and given advice on concrete mix proportions. Well-trained local craftsmen must supervise the mixing and placing of the concrete in the slab.

Superstructure

A superstructure can be built of any local material. It needs to provide adequate privacy and should be constructed with a floor, walls and a roof. Improved ventilation and other modifications will help to control flies and odours.

Latrine design

The following technologies can use interchangeable designs of pit, slab and superstructure.

Basic pit latrine

A basic pit latrine comprises of a pit, slab and superstructure, built using whatever local materials are most appropriate. It is recommended that latrines are upgraded from this basic design, as it is susceptible to flies and odours.

Ventilated improved pit (VIP) latrine

The ventilated improved pit (VIP) latrine was introduced in Africa in the 1970s and has proved successful in overcoming problems with flies and odours.

The interior of the superstructure must be well ventilated and darker than daylight outside. The pit must have a ventilation pipe which should be at least 100mm in diameter and extend

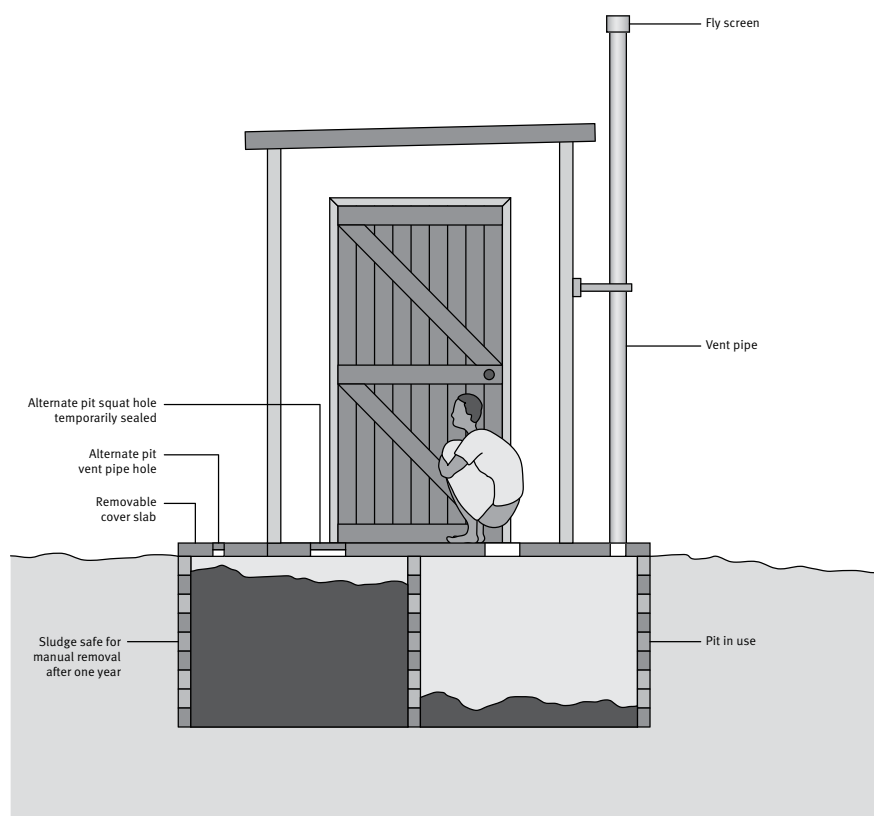

Fig 1: Ventilated improved pit (VIP) latrine

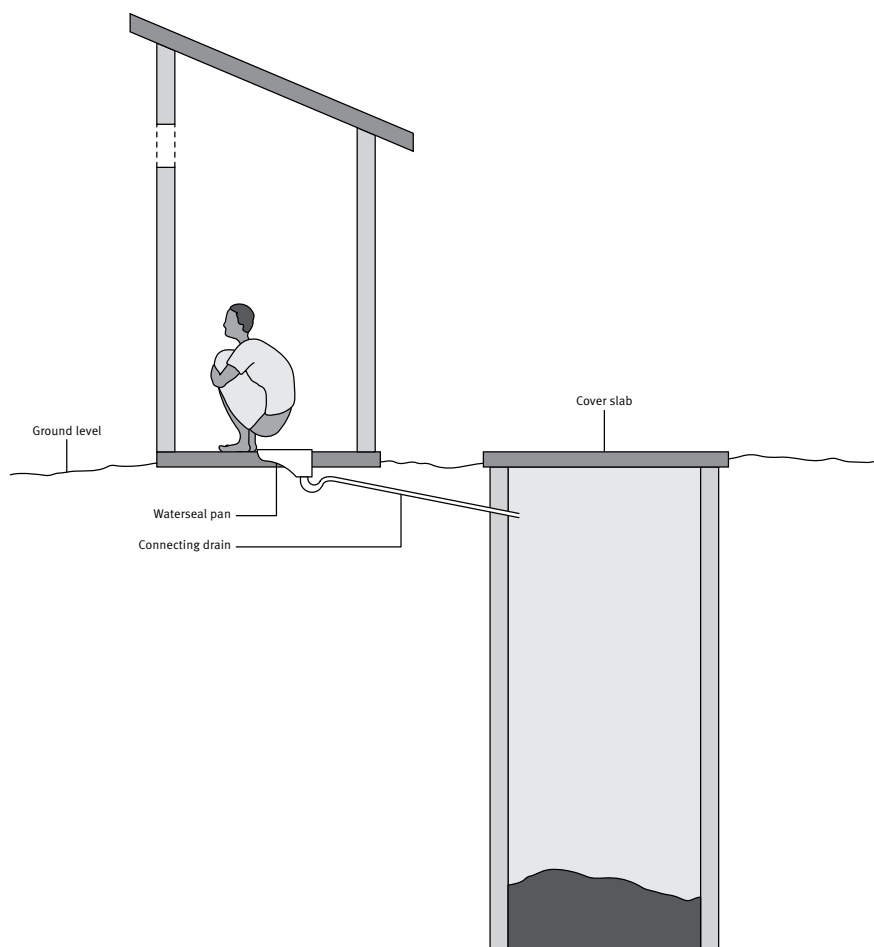

Fig 2: Pour flush latrine

from the pit to about 0.5m above the roof. The top should be fitted with a fine-mesh stainless steel, GRP or aluminium fly-screen. Flies attracted by smell into the pit will be drawn up the pipe by the daylight at the top of it, and get caught by the screen. Wind passing over the vent pipe will also cause an up-draught, removing any smell and helping to draw up flies. The door access should ideally face into the prevailing wind direction to maximise the dispersion of odour. However if the prevailing wind direction means the access faces the living area of the community, a curved entrance should be considered for extra privacy.

Pour flush latrine

In villages where people use water for anal cleansing, pour flush latrines can be more appropriate. The squatting slab is sited a metre or two away from the pit, which it drains to via a communication pipe. To prevent smells rising from the pit, a U-bend water seal can be incorporated or a close-fitting squat-hole cover fitted.

For a double pit design, a drain junction will be needed to block the pipe to the pit not currently in use.

Ecological sanitation

Ecological sanitation is the principle of returning the nutrients contained in human waste to the land. These latrines are often referred to as 'eco-san' latrines and are designed to biodegrade human waste into a humus-like soil which is safe to handle, rich in nutrients and can be used to increase agricultural production. In this system, urine and faeces are seen as a resource rather than a waste.

Composting latrines

A basic composting latrine has the same design as a basic pit latrine. A handful of a mixture of soil and ash is added to the pit after each use to keep the pit dry, which limits odours. Other organic material can also be added, such as leaves, grass clippings and vegetable waste, to aid composting. After being left to decompose for 12 months, the resulting compost can be dug out and applied to the land as a fertilizer.

The composting toilet is not appropriate for greywater disposal. For this reason water used for anal cleansing should be diverted where possible, although small amounts can be tolerated.

A variation on the basic composting latrine is called the **Arborloo** where the superstructure and slab are removed to a new pit once the old pit is two thirds full. The old pit is then filled up with soil and a tree is planted inside.

The **Fossa Alterna** is a design with two pits which are used alternately. One pit is used until it is full and then the second pit is used while the first pit rests. Just before reuse the resting pit is emptied and the dug out compost can be used as fertiliser.

Fig 3: Arborloo

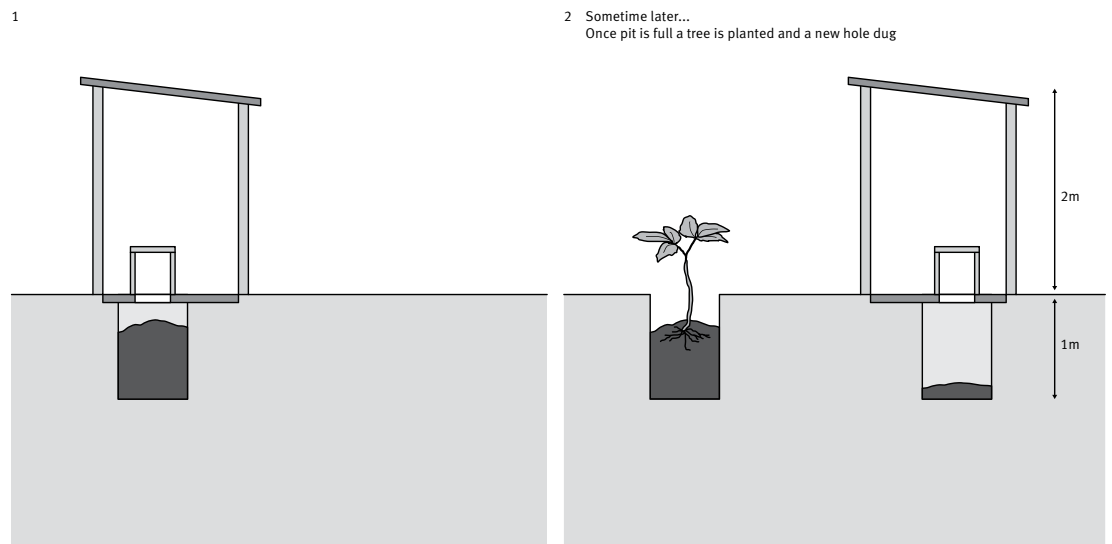
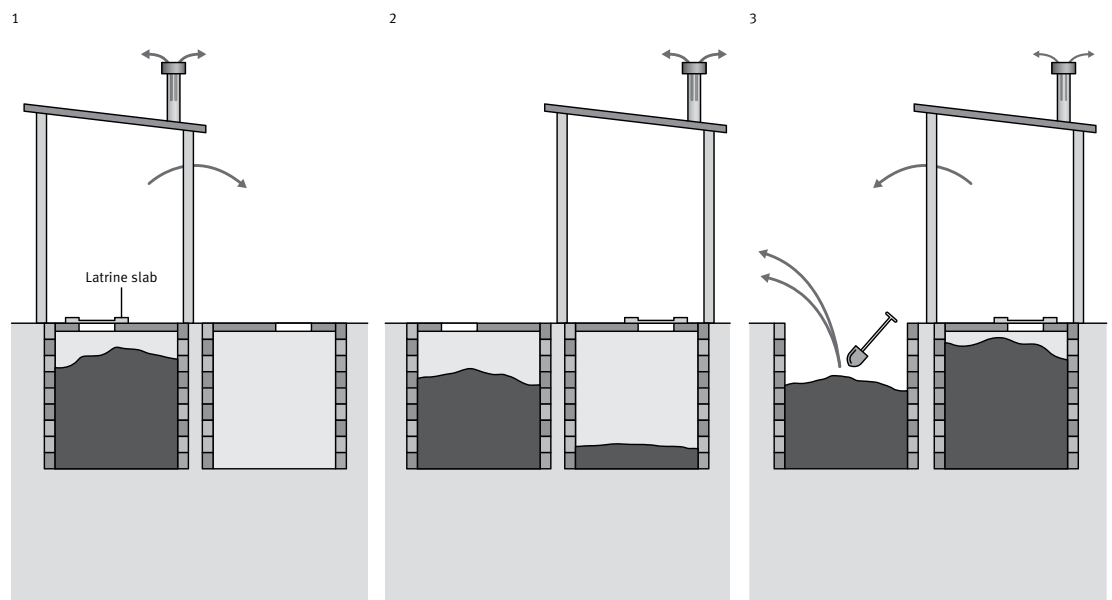

Fig 4: Fossa Alterna



Urine-separating latrines

This latrine separates urine and faeces by a urine diverting slab or pan. Faeces drops into a vault, where they are stored until all pathogens are destroyed and it is safe for application to land and crops. The decomposition process is aided by the application of soil, ash or lime after each use. It is essential that no water is allowed to enter the vault. Urine is collected separately and can be diluted and applied to crops. Whilst urine is theoretically sterile, it

is advisable that it is left for a short time before use, in case of possible contamination.

These toilets are often built above ground, making them appropriate for rocky areas or locations with a high water table.

Vaults can take the form of buckets or tanks. If the vault is large, then the dry matter should be periodically spread about with a pole to prevent build up in the centre and to facilitate drying.

Fig 5: Urine-separating latrines

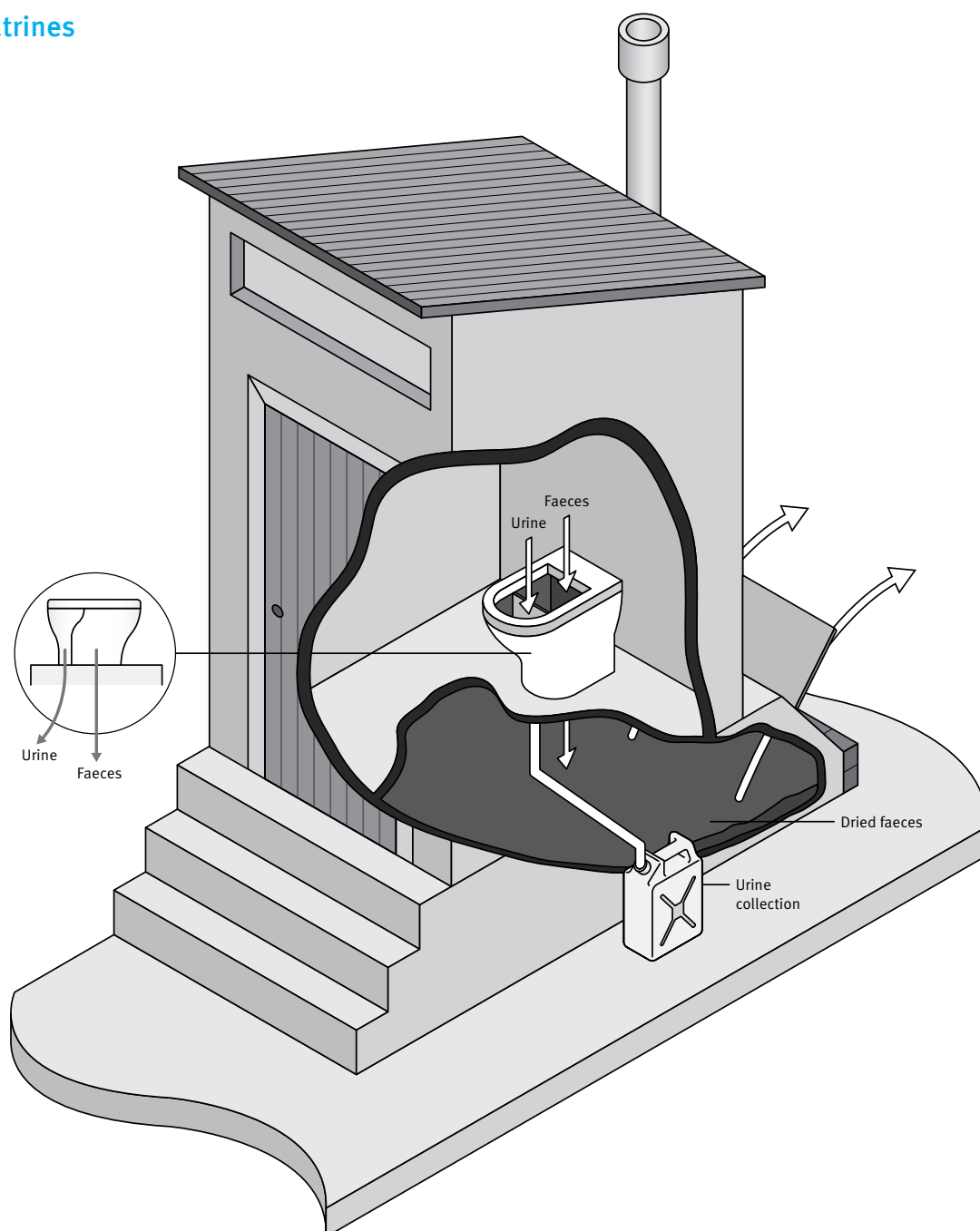

Advantages of Ecological Sanitation:

- ✓ Creates fertiliser which can be used in agriculture
- ✓ Cheap to build and maintain
- ✓ Does not require water
- ✓ Double pits used alternately have a virtually unlimited life
- ✓ No problems with flies or odours if used correctly

Disadvantages of Ecological Sanitation:

- ✗ Some communities unwilling to accept the reuse of faeces
- ✗ Requires ash, sand or lime
- ✗ Cannot be used for disposal of greywater or anal cleansing water
- ✗ Requires education and acceptance to be used correctly
- ✗ Requires commitment to maintenance

opinions on exactly how far is safe; however, 50m is generally considered to be adequate).

- A buffer zone of 1.5m between the base of the pit and the water table should be ensured to minimise contamination; however, this is subject to the type of aquifer/soils and hydrogeological advice should be sought.
- Pits in unstable soils should be fully lined. Unlined pits should be circular and should not exceed 1.5m in diameter.
- Measures should be taken to prevent rainwater, soil and rubbish from entering the pit.

General latrine construction

Full-scale demonstration latrines, preferably showing the range of designs for latrine slabs, should be built in each village before the start of a sanitation project. It is vital that the families should be enabled to provide themselves with what they are happy with, and not with what is thought good for them. Each family should be given detailed advice on the siting of pit latrines (preferably downwind, away from trees and not too close to places where food is stored or prepared).

The following points are also important to consider and explain to the community when designing their latrine:

- Pit latrines should be located for convenient access by sludge removal vehicles where required.
- Twin pits are preferable where possible.
- Pit latrines should not be built near trees to prevent tree roots damaging the pit
- Pit latrines should be sited downhill and a good distance from the nearest well or borehole used for water supply (there are varying

Choosing a latrine type

As well as household preferences there are often external reasons which influence the choice of sanitation technology. Examples of these are given below. A compendium of different technologies should be used to inform any decision, such as the Sandec/EAWAG tool.

- Ground conditions and groundwater level: For example, in areas of high groundwater ecosan should be considered with a raised latrine structure. This allows for a shallower pit and less pollution from pit contents.
- Density of settlement: Depending on the density of a settlement, latrines may not be able to be dug fresh each time one is filled. The method by which a latrine will be emptied should determine its design.
- Market for compost and/or fertiliser: If there is no end user for the compost from a composting latrine then this may not be an ideal solution, as the waste product will still need to be disposed of. The extra work required to manage a composting latrine needs to be offset by a useful end product.

Case study Ecosan in Malawi

This project in Chikompulazi village in Malawi started in 2008 and focused on sanitation with a marketing approach. People are encouraged to choose their latrine type, with this attributed to status within the village. Ecosan is particularly encouraged. The promoter charges for the latrine slabs. If people can't pay at the time they can pay with either the compost produced or with the first fruits of the banana tree they plant using the compost.

Many people here used to practice flying toilets but since the project some have started to build Ecosan latrines.

Alice Mbewe, 35 says: "I am married with five children. This is the second month that I have had the new ecosan latrine. I decided to get it because I can use it again, it is cheap and there are no flies. Also before the holes were deep so it was dangerous for the children. The old one smelled too, too much, this new one doesn't smell at all and sits on a different site from the old one. When the manure is ready I will take it to the garden to grow maize, I grow it for selling and eating. When I first heard about human manure I had a bit of a problem but it didn't smell so much so I thought it would be ok. When you take the manure you make ridges, put in manure then your maize and it grows up very well."



WaterAid/Layton Thompson

Alice Mbewe washing her hands in front of her latrine, Chikompulazi village, Mzuzu, Malawi



Fig 6: Tippy-Tap

A note on hygiene

It is very important to place handwashing facilities near to toilets. An example of basic handwashing facilities is the Tippy-Tap – a plastic bottle suspended on a Y-shaped stick or string with soap attached, which can be tipped over to pour out water without touching or contaminating the bottle.

A note on equity and inclusion

When thinking about latrine design, consideration should be made for access and ease of use. A latrine should be sensitive to both genders and local culture. Specific attention should be given to menstrual hygiene issues. Users with special needs should be provided with an opportunity to design their own adaptations for latrines. See the 'Social exclusion' section of the WaterAid website.

References

- Pickford J (1995) *Low-Cost Sanitation*, IT Publications
- Winblad U and Kilama W (1985) *Sanitation without water*, Macmillan Education
- Brandberg B (1997) *Latrine Building*, IT Publications
- Reed R A (1995) *Sustainable Sewerage*, IT Publications
- Mara D (2004) *Domestic waste water treatment in developing countries*, Earthscan
- Morgan, Peter, 2007. *Toilets that Make Compost: Low-cost, sanitary toilets that produce valuable compost for crops in an African context*. Stockholm Environment Institute, Sweden. Available at http://www.ecosanres.org/pdf_files/ToiletsThatMakeCompost.pdf
- Tilley, Elizabeth et al, 2008. *Compendium of Sanitation Systems and Technologies*. Swiss Federal Institute of Aquatic Science and Technology (Eawag). Dübendorf, Switzerland.

Useful resources

- Sanitation portal of Akvopedia
<http://www.akvo.org/wiki/index.php/Portal:Sanitation>
- The United Nations Environmental Programme – International Source Book on Environmentally Sound Technologies for Wastewater and Stormwater Management. Available at:
http://www.unep.or.jp/ietc/Publications/TechPublications/TechPub-15/main_index.asp
- The World Health Organisation – Fact sheets on environmental sanitation. Available at:
http://www.who.int/water_sanitation_health/emergencies/envsanfactsheets/en/index.html
- EcoSanRes: Closing the loop on sanitation
<http://www.ecosanres.org/>
- Eco-solutions
<http://www.eco-solutions.org/urbanecosan.html>



WaterAid transforms lives by improving access to safe water, hygiene and sanitation in the world's poorest communities. We work with partners and influence decision-makers to maximise our impact.

Registered charity numbers:

Australia: ABN 99 700 687 141

Sweden: Org.nr: 802426-1268, PG: 90 01 62-9, BG: 900-1629

UK: Registered charity numbers 288701 (England and Wales) and SC039479 (Scotland)

US: WaterAid America is a 501(c)(3) non-profit organization