

Urban pit waste management

Part of a series of WaterAid technology briefs.

Available online at www.wateraid.org/technologies

January 2013

Introduction

All pit latrines, septic tanks and aqua privies will eventually become full of accumulated sludge. Before construction starts, good designers will have made a decision as to whether or not the unit is to be emptied or moved. With septic tanks and aqua privies the decision is straightforward; they are designed to be emptied periodically. The decision for pit latrines is not so simple. It will depend on the latrine design, location and customs of the users. However, in urban areas it is likely that there is no land available to dig a new pit, so it will be necessary to arrange for a pit to be emptied as soon as it is full. The users need to be made aware of this requirement and to have formulated a workable method of emptying and disposing of pit wastes during the project planning stage.

This Briefing Paper looks at the options available for **urban pit waste management**, including various pit emptying methods and options for sludge disposal.

How it works

Emptying full single pit latrines can cause a serious health hazard, as the freshly deposited sludge at the top of the pit will contain many faecal organisms that may be pathogenic. Twin pit latrines are designed to be emptied without the need to handle fresh excreta. Removal of dried sludge from a pit that has been left undisturbed for two years should be relatively straightforward as the material will have decomposed sufficiently and be relatively safe to handle (although care should still be taken to minimise contact).

The sludge and scum from septic tanks is relatively easy to remove because of its high liquid content. A septic tank or aqua privy serving a communal latrine will probably fill very quickly so it is very important that the emptying method is well designed and can be repeated at regular intervals.

Materials and construction

There are two parts to be considered in a pit waste management strategy: how to empty the pit and how to dispose of the material removed, including how to transport it.

Pit emptying

There are two choices for pit emptying: motorised emptying or human-powered emptying.

Motorised emptying

A vacuum truck or tanker is a motorised vehicle equipped with a pump and a storage tank. The pump is connected to a hose which is lowered down into a constructed tank (e.g. septic tank, aqua privy, etc.) or pit, and the sludge is pumped up into the holding tank on the truck. Generally the storage capacity of a vacuum tanker is 3-10m³ so large septic tanks may require a truck to return more than once to fully empty the tank.

Although smaller more mobile pumps have been developed, large vacuum trucks are still the norm. Unfortunately, the large trucks often have difficulty accessing pits/septic tanks in areas with narrow or non-driveable roads. Depending on the collection or treatment technology, the material in the tank or pit can sometimes become so compacted that it can not easily be pumped.

Vacuum tanker emptying a septic tank

Source: http://www.who.int/water_sanitation_health/hygiene/om/linkingchap8.pdf

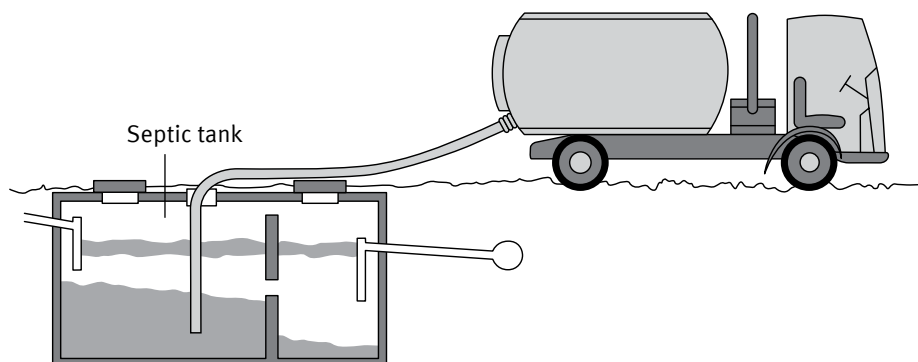

In these situations it is necessary to thin the solids with water so that they can flow more easily, but this is inefficient and potentially costly. If water is not available, it may be necessary for the waste to be manually removed.

Human-powered emptying

Manual emptying of pits is done either by hand using buckets and shovels or using a portable, manually operated pump (such as the MAPET: Manual Pit Emptying Technology).

Some pits can only be emptied manually, for example, material left to decompose and dry out in a twin pit system or Fossa Alterna. These technologies require manual emptying (with a shovel) because the material is solid and cannot be removed with a vacuum pump.

Technologies that are water-based, for example a septic tank or aqua privy, should be emptied with either a MAPET (or similar device) or with a vacuum truck. Water-based technologies should generally not be emptied by hand because of the high risk of collapse, toxic fumes, and exposure to the hazardous sludge.

A MAPET is comprised of a hand pump connected to a vacuum tank which is mounted on a pushcart. A hose is connected to the tank and is used to suck sludge from a pit. When the hand pump is turned, air is sucked out of the vacuum tank which in turn sucks sludge up into the tank. Depending on the consistency of the sludge, the MAPET can pump up to 3m. The MAPET is especially suited to dense, urban and informal settlements that are not easily accessed by vacuum trucks. In areas that have difficult terrain or are too densely populated to be accessed by a vacuum truck, manual emptying is a viable option.

Despite the technical success of MAPET technology, they are still not widespread due to cost, speed and institutional constraints that have prevented its widespread acceptance. It is critical then that locally-made, innovative solutions are found that can be owned and operated in the community. WaterAid experience of pit emptying in Maputo, Dhaka and Dar es Salaam with both the Vacutug and MAPET has identified the need for an alternative pit emptying technology with the following characteristics:

- Able to gain access without demolition of property.
- Able to handle waste without requiring direct contact by humans.
- Manufactured and maintained locally.
- Cost less than \$2000.
- Sufficiently light weight that it can be carried across the shoulder.
- Operable by one man.
- Sufficiently robust to allow for neglect and misuse.
- Capable of emptying at least the top metre of the pit.

The MAPET: Manual Pit Emptying Technology

Credit: Eawag/Sandec, 2008. Compendium of Sanitation Systems and Technologies



The Gulper was designed on these principles, for use in Dar es Salaam. Based on the MAPET technology it has a lower capital cost, is easy to maintain, easy to transport, and is small enough to be operated by one man. Further details are given in the Case Study.

Sludge disposal

Removal and disposal of sludge removed from pits and tanks is a complicated issue. It is regarded as unpleasant, dirty work and the people who do it carry with them a negative social stigma. To compound the problem they are often forced to work at night to avoid causing a disturbance to residents, in crowded, unlit neighbourhoods pushing barrows or manoeuvring vehicles through narrow lanes. Accessing suitable disposal sites nearby is also a major problem. Consequently the sludge is often neglected and illegal dumping of the waste is common. Alternatively the pits are not emptied at all; they fill up, overflow and become unusable. Giving the matter careful consideration at the system design stage and planning a safe, practical, affordable method of disposal will reduce the likelihood of this happening.

Sludge that has been left undisturbed for two years is not a hazard to the environment, and can safely be spread on a garden or on a refuse tip. Decomposed sludge can add humus and fibre to the soil which will promote plant growth. Sludge containing plastic bags, stones and other solids will be less useful as they will be environmentally intrusive if spread on open ground; this material should be buried.

Open disposal of fresh sludge into water or onto land is an environmental and health hazard. The best solution is to bury the sludge in pits so that it cannot come into contact with humans or animals. Alternatives are to mix it with the influent at a nearby sewage works or compost it with domestic refuse. Limiting the distance the sludge has to be transported to the disposal point will greatly reduce costs and will increase the likelihood of proper disposal being carried out.

For human-powered emptying a travel distance of no more than 0.5km is considered to be a practical guide.

Development of transfer stations can help improve sludge management. Transfer stations are discharge points for faecal sludge and septage into conventional sewers that are then connected to a centralised treatment plant. The transfer station can either be directly connected to a sewer main, or can be a large storage system that can be operated to release the waste into the sewer main at controlled intervals. This will improve treatment performance and reduce peak loads. Transfer stations are especially appropriate

for dense, urban areas where there is no alternative discharge point and may help to reduce the incidence of illegal sewage dumping. The location must be carefully chosen to maximize efficiency, while minimising smells and disturbances to nearby residents. Furthermore, if the utility responsible for sewers and sewage treatment can be persuaded to build transfer stations near to low-income communities and to offer incentives to increase their use, then it may be possible to significantly improve the health of a community by providing an inexpensive, local solution to faecal sludge and septage disposal.

Advantages and disadvantages

	Advantages	Disadvantages
Human-powered emptying	<ul style="list-style-type: none"> • Useful for serving sections of the population which would otherwise go unserved. • Potential for local job creation and income generation. 	<ul style="list-style-type: none"> • Time consuming: can take several days depending on the size of the pit. • Hard, unpleasant work. • MAPET requires some specialised repair (welding). • Requires a disposal point or discharge area; sludge transport over 0.5km is impractical. • Sludge must be carried/pushed offsite which is difficult and time consuming. • Spillage and bad odours are likely.
Motorized-emptying	<ul style="list-style-type: none"> • Fast, and generally efficient. • Minimizes risk of contact with unhygienic material. • Depending on the political/economic structure, vacuum truck enterprises can benefit a community and be a source of sustainable income. 	<ul style="list-style-type: none"> • Expensive operating and maintenance costs that are passed onto the customer; not all customers can afford the service. • Cannot pump thick, dried sludge (this must be manually removed). • Very high capital costs. • Because of access, location, or economics, not all trucks discharge to a suitable facility. • Pumps can usually only suck down to a depth of 2-3m and the pump must be located within 30m of the pit.

Capital and operational costs

A new Vacutug can cost anywhere from \$20,000 to \$100,000, although new trucks are rarely purchased. Used or self-modified trucks are more common and cost in the region of \$8,000 to \$10,000. A MAPET will cost around \$3,000 and a Gulper a little less at around \$2,000. Both can be fabricated locally. A shovel, drum and cart for hand-emptying will cost about \$150.

Operation costs of the Vacutug are very high compared to the MAPET, Gulper and hand tools. These will be mainly vehicle maintenance, fuel and oil, but bribing/paying local authorities to obtain licenses and permission to discharge contents will incur large expense too.

References and further reading

Brikké F and Bredero M (2003) *Linking technology choice with operation and maintenance in the context of community water supply and sanitation: A reference document for planners and project staff*. WHO and IRC Water and Sanitation Centre, Geneva, Switzerland. Available at: www.who.int/water_sanitation_health/hygiene/om/wsh9241562153/en/index.html

Building Partnerships for Development (no date) *Sanitation partnerships: Dar es Salaam case study*. Building Partnerships for Development, London, UK. Available at: www.bpd-waterandsanitation.org/bpd/web/d/doc_117.pdf?statsHandlerDone=1

Eales K (2005) *Bringing pit emptying out of the darkness: A comparison of approaches in Durban, South Africa, and Kibera, Kenya*. Building Partnerships for Development, London, UK. Available at: www.bpd-waterandsanitation.org/bpd/web/d/doc_131.pdf?statsHandlerDone=1

Eawag and Sandec (2008) *Compendium of sanitation systems and technologies*. Available at: www.sustainable-sanitationalliance.org/documents/5thmeeting/minutesdocs/en-wg4-compendium-forreview-2008-02-28.pdf

Franceys R, Pickford J and Reed R (1992) *A guide to the development of on-site sanitation*. World Health Organisation, Geneva, Switzerland.

Reed RA (2000) *Low-cost sanitation*. WEDC postgraduate module course notes. WEDC, Loughborough University, UK.

Sugden S (2007) *Presentation: WaterAid urban excreta management*. WaterAid, London, UK.

Case study

WaterAid’s experiences in Maputo, Mozambique

The pit emptying service in Maputo started in 2000 in an unplanned area of Maputo called Urbanização, after it was affected by a cholera epidemic. WaterAid had been working with a local community-based association called ADASBU to provide a range of water and sanitation services to Urbanização, including over 440 latrines. The latrines take between two and five years to fill after which they must be emptied if they are to be used. The high water table in this area means the latrines fill quicker than usual.

Pit emptying was previously done by hand which was both unsafe and ineffective. There was also limited access for the trucks that transported the collected sludge. WaterAid and ADASBU introduced the Vacutug. The Vacutug is a motorised machine fitted with a 500 litre tank and a pump. It is small enough to move around the narrow roads of the unplanned settlements.

As a result of the success of this technology, several more have been purchased for this and other settlements. When a household needs the emptying service they contact ADASBU which arranges for the Vacutug to visit the latrine and bring the sludge to a 15,000 litre holding tank. When the holding tank is full, a tractor takes the waste to the sewage treatment plant.

When the emptying was done manually, fees of \$1.85 to \$5.50 were charged depending on the size of the pit. The prices now are \$7.40 per 500 litres within Urbanização, but the system is a lot more sustainable and there is a market for it.

Some of the challenges faced by ADASBU in this process were the lack of spare parts for the Vacutug and the cost of the spare parts for the tractor. Nevertheless, ADASBU has been trying to overcome these problems by converting some of the key components of the machines or replacing them with those available in the market to keep the business going.



Credits: Eawag/Sandec, 2008



WaterAid transforms lives by improving access to safe water, hygiene and sanitation in the world's poorest communities. We work with partners and influence decision-makers to maximise our impact.

Registered charity numbers:

Australia: ABN 99 700 687 141

Sweden: Org.nr: 802426-1268, PG: 90 01 62-9, BG: 900-1629

UK: Registered charity numbers 288701 (England and Wales) and SC039479 (Scotland)

US: WaterAid America is a 501(c)(3) non-profit organization